

ERRA DELTA

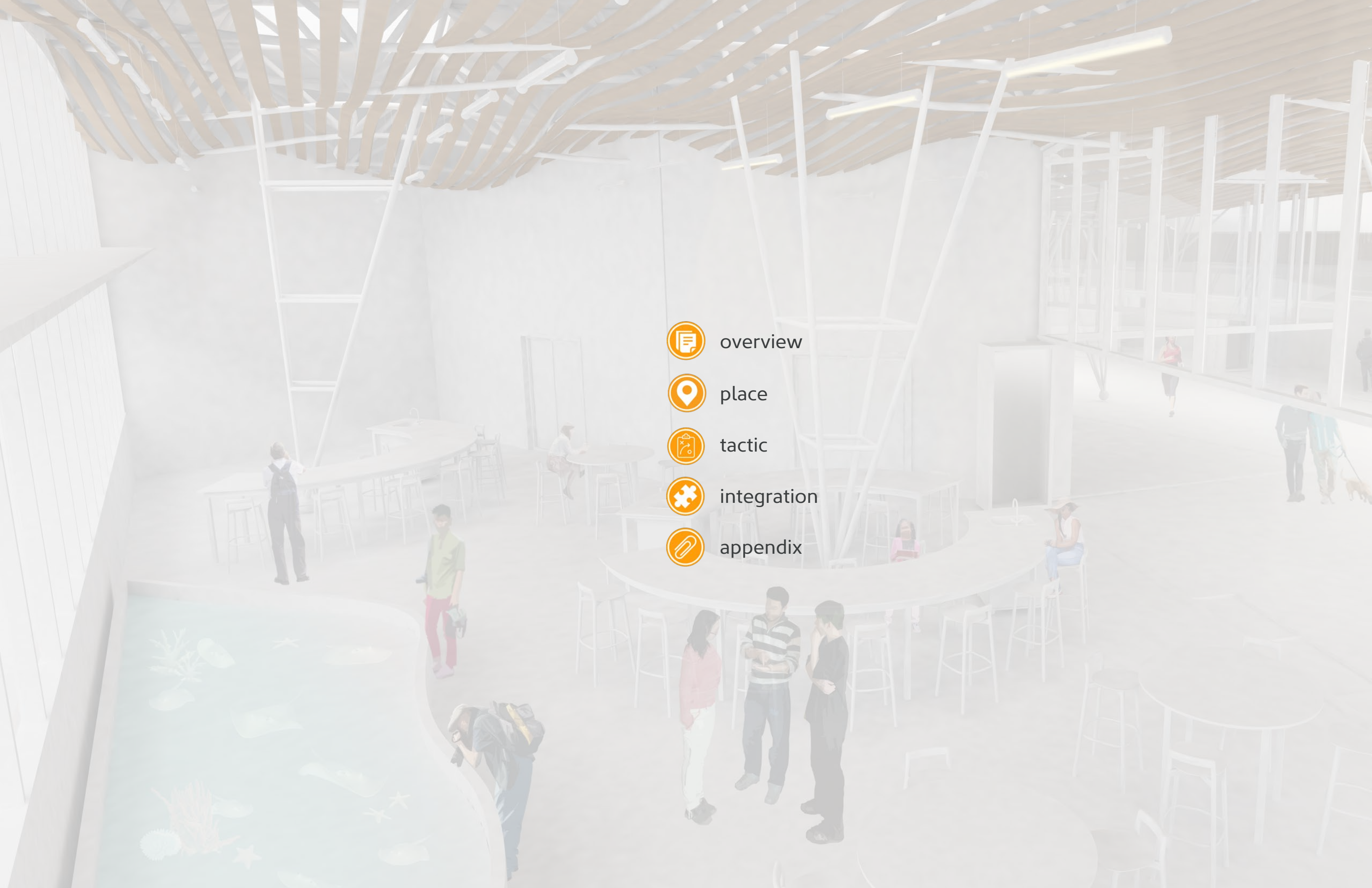



overview



place



tactic



integration



appendix



OVERVIEW

TERRA DELTA brings together the poetics of design and the integration of systems to develop an architecture that is conducive to both the environment and its inhabitants.

In appreciation of the drastic landscape of Tiburon and its vantage points of the bay, TERRA DELTA became a reflection of observation after visiting the site. Its structure not only mimics the undulations of the topography, but it gives way for an optimum renewable strategy to all systems.

The architecture is stitched into the Romberg Tiburon urban fabric, nestling itself into the hillside for ideal views of the San Francisco bay. Its programmatic elements frame these views, as well as, face one another for a permeable circulation. These choices emphasize the need for a self-guided campus and interactive learning with the bay.

TERRA DELTA receives its name from the two main fascinations: the dramatic topography and the circulation of its inhabitants. The architecture acts as a delta to its visitors, pulling people in and feeding them to the bay with the outdoor terrace as its palette.



 OVERVIEW



PLACE regional

TERRA DELTA is nestled in the edge condition of Tiburon, ca, just north of San Francisco. This area plays a major role in the bay area; an area that embraces sustainable urbanization. The renewable attitudes of the west coast stand apart from most other areas in the United States, to that which it is a privilege to design in.

At a regional scale, the bay area is framed by fault lines and vastly changing elevations. Offering many different urban climates in its perimeter, the bay area houses important ecosystems that allow its originality to rise above the rest.



PLACE regional

As an immensely large delta system and watershed, the Romberg Tiburon Maritime Studies Campus enjoys a prime location along the border between the two undulating forms of the San Francisco Bay and the Tiburon landscape.

A site worth celebrating, the access to water and abundant opportunity for education is not only clear but exciting. Water is the most important resource to humanity and our Earth, as it is also the reason for the Maritime Studies program. In its importance, water is a driving force in the TERRA DELTA systems, operations and goals of environmental neutrality/benefit.





PLACE site

The Romberg Tiburon Center for Environmental Studies is the site of the San Francisco State University's center for estuary and ocean science. 3152 Paradise Drive has a 40% grade slope from the waters edge to the main entry road. The school is able to practice marine studies, here, at the edge of the bay. Its access to the water and rich site history give the center a unique canvas to work with.

The drive onto the campus conducts a gorgeous entry sequence. The landscape and tree canopy opens up into a view of the seascape; the San Francisco Bay Delta and its connection with the maritime studies landscape.

This experience from the entry to the site introduces the program that is meant to carry through the TERRA DELTA facility and its undulating landscape.



PLACE site

The site strategies for TERRA DELTA include a landscaping system of drought-resistant vegetation that aids in storm water management along the stark drops in the landscape. To make use of the hillside, a series of switchbacks narrate the landscape and provide gentle resting places and lookouts on the journey between the main parking and the proposed architecture.

Moving from ADA parking to the campus, the materiality of the ground cover transitions from loose aggregate to a polished exposed aggregate. At the edges of the paving, rock beds rests to provide a second layer of rainwater management.

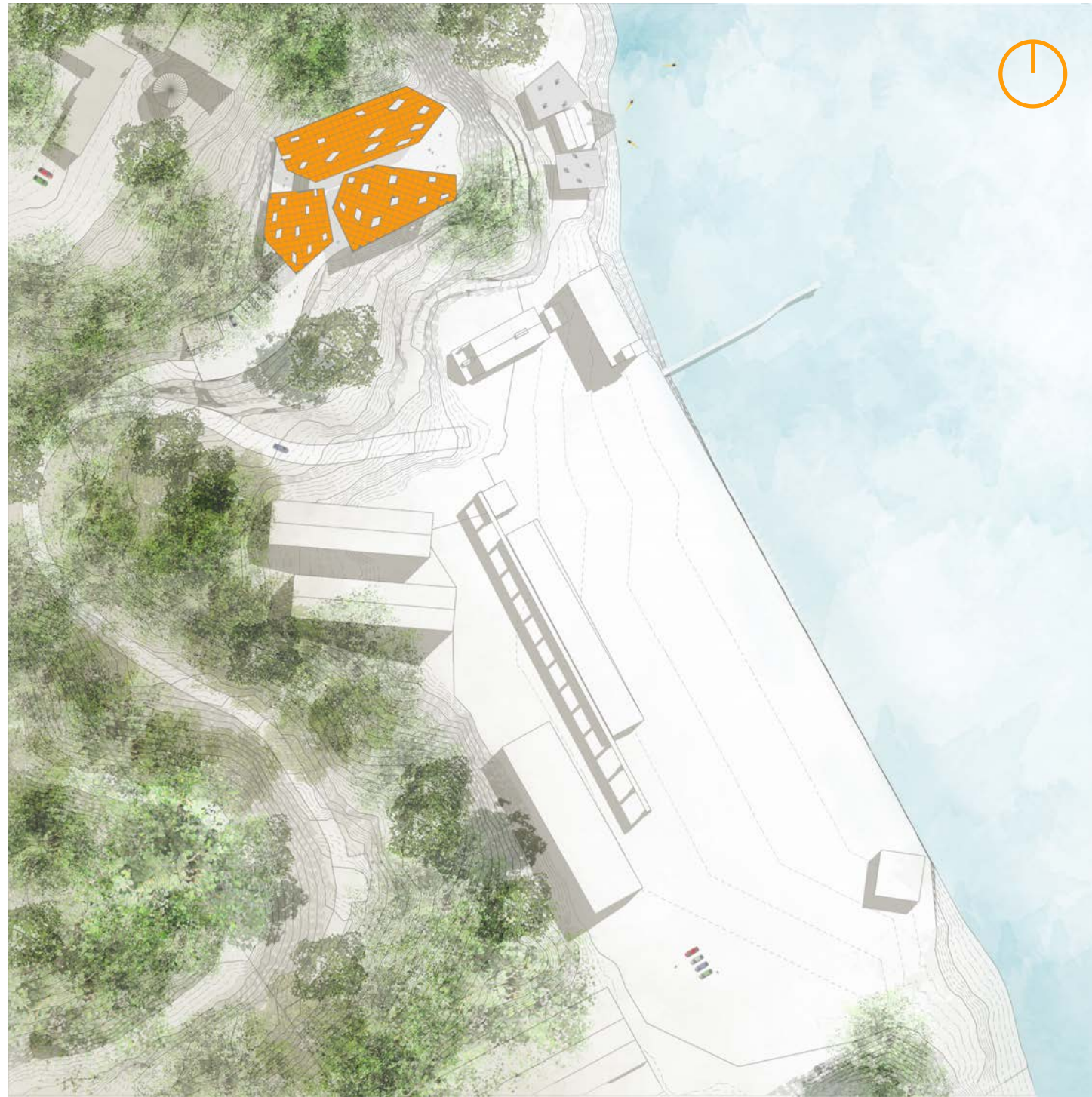



TACTIC narrative

A continued landscape.

The most prominent aspect of the site is the sheer elevation and rugged textures embedded in its heart. From this striking infatuation derived a structural system that mimicked the undulations within the landscape.

As stated previously, TERRA DELTA receives its name from this fascination in the landscape and the circulation of its inhabitants. The architecture acts as a delta to its visitors, pulling people in and feeding them to the bay with the outdoor terrace as its palette.

Open program and communication between spaces creates a canvas that encourages the regular employees, students, visitors and any other inhabitants to connect and learn as they interact with the environmentally beneficial facility that is TERRA DELTA.





TACTIC structure

The design of the structure and enclosure as one coexisting system evolved through a process of observing the narrative for the TERRA DELTA facility. The desire for an open, flowing program was solved with a structural space frame system which conducts and informs the activities and aesthetics of the maritime studies facility. The structure allows for enhanced sustainability performance, lighting and daylighting, conditioning and spatial connections.





TACTIC structure

A space frame was created with intent of parametric construction and customized integrity. The white-coated steel space frame undulates with the landscape and tree canopy that surrounds the site. Its materiality provides the ideal structure and spanning capabilities, as well as, optimizes the use of light as a diffusing chamber.

The system appears to be floating, as it is not supported by generic columns, but rather a continuation of a space frame unit that extrudes to the slab. The columns are supported by a ball joint connection that alters the directionality of the columns, as if the structure is walking with the visitor through the site.

Just below, a dispersed, wood lattice system offers a gentle and warm veil to the space frame, allowing for the undulations and light qualities to adjust based on the angle of the inhabitant.

The exterior envelope of the roof consists of standing-seam metal. This allows for a slight alternative to the existing materiality of the Romberg Tiburon site. The standing seams also directs rain water along the sloped roof towards the main drain channel of the facility.

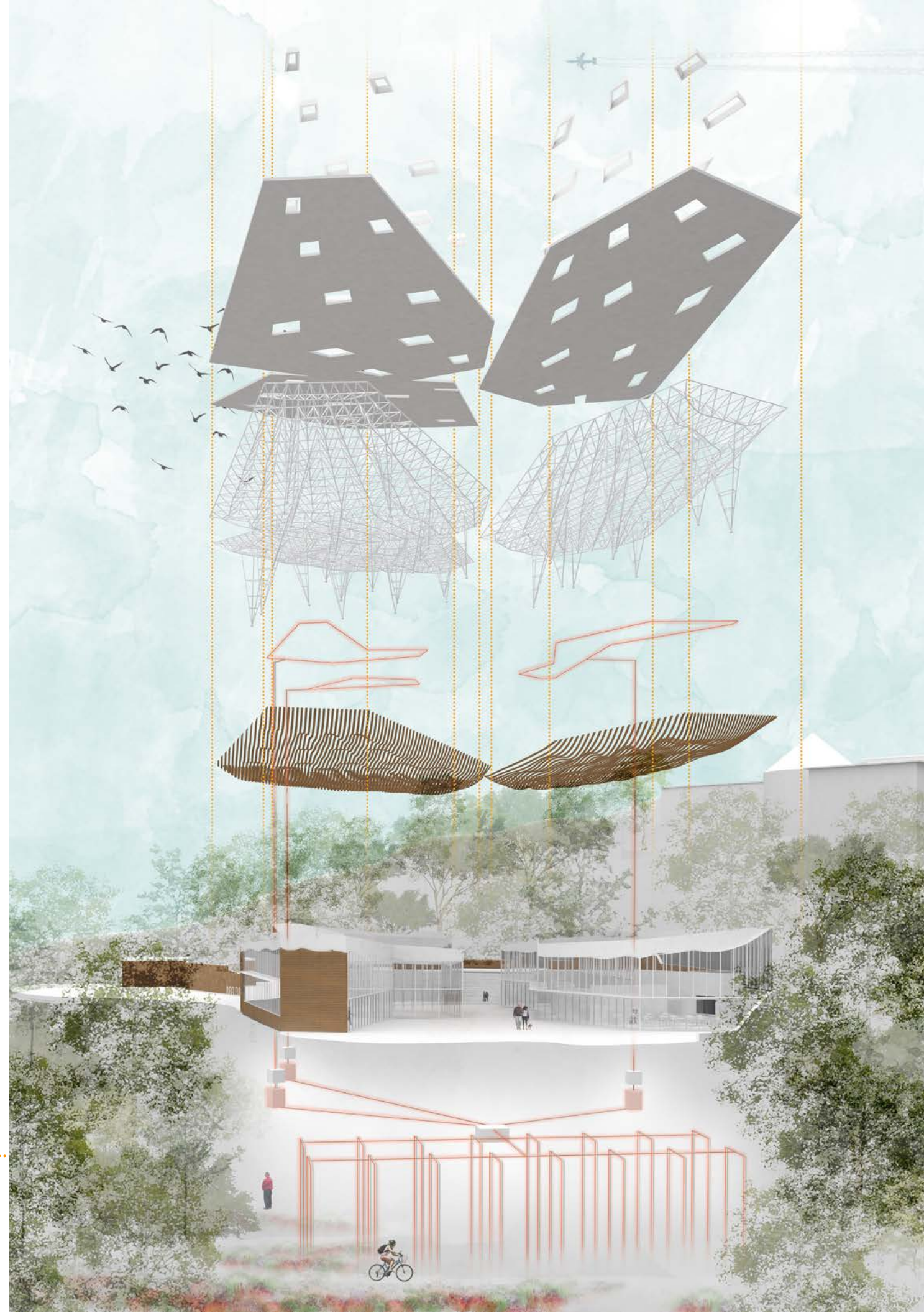



TACTIC program

As a bay-side community education and visitor's center, it is vital that the programmatic elements are interactive with the bay at a scale of view and study. As the structure and systems unite interior and exterior to achieve net neutrality, the goal of the program was to extend education and enjoyment from interior to exterior and vice versa.

The program of spaces was connected to the narrative such that the program, as a whole, involves a central hub and circulation delta that connects occupants with maritime studies and the landscape and seascape around them.

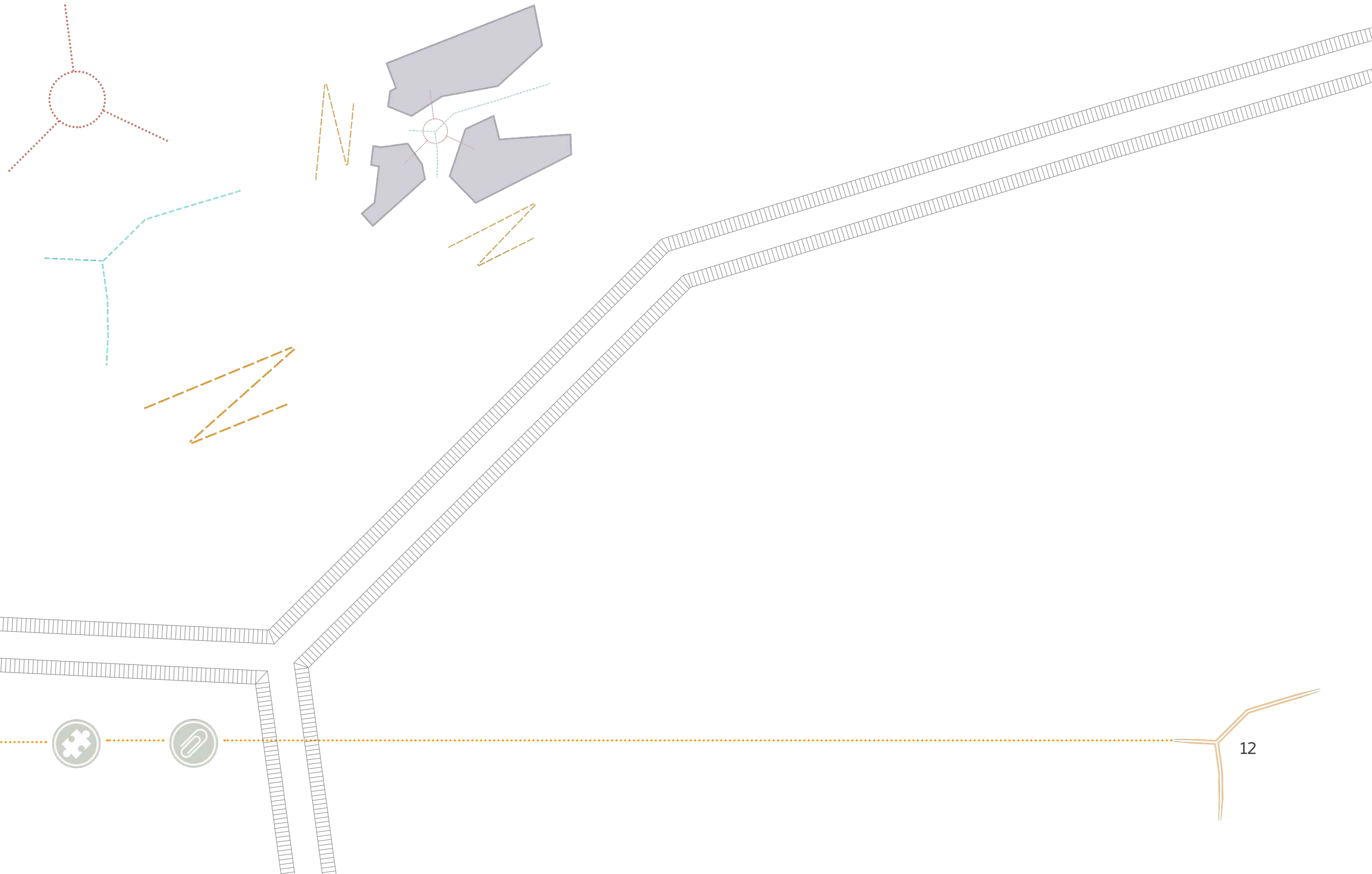

TACTIC program

With the desire for the architecture to encourage a self-guided circulation, the program was divided into a tri-building campus. The three forms were spread and carved to create a "program hub." This southwestern space serves as an anchor to the architecture and lends itself to a convenient meeting place, gathering spot for field trips, or simply a place of reflection and relaxation.

Widening from the hub, the two western access points to the facility filter in and push out towards the bay, acting as a delta to the visitors. This action is also narrated by the rainwater collection and exterior drainage system.

The facades that face the interior of the campus consist of a nanawall system. Although the programs are divided into their prospective areas, the collapsing facade gives way to a permeable program.

For example, the wet lab opens up to the delta, allowing for visitors to flow out to the bay. This promotes interactive learning with the San Francisco bay acting as the "fourth wall," the seascape.



#. Main Program Space

- important aspects
- design descriptions

1. Wet Lab

- circular group seating
- panoramic view of campus and the bay
- nanawalls opening up to exterior covered space for outdoor learning

2. + 8. Exhibit and Support

- long space exposed to central, outdoor space
- nanawall system opens space to exterior

3. Multi-Use

- central location (ideal for events)

4. Welcome+Retail

- borders both entry locations
- nanawall system on central wall

5. Admin

- open seating plan
- windows + clerestories for optimum daylighting opportunity

6. + 7. Dining and Kitchen

- views of courtyard and bay
- flows into exhibit space



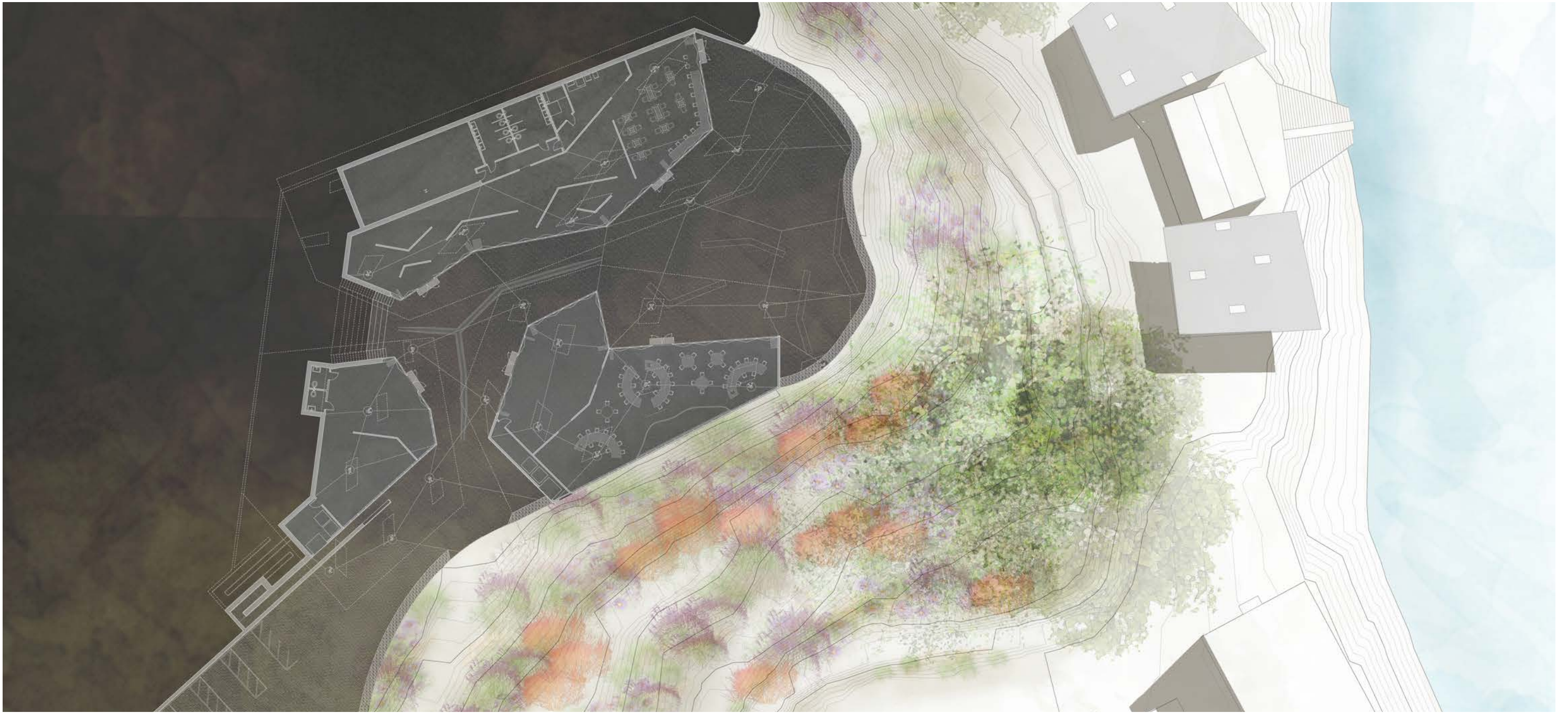



INTEGRATION passive

Due to the optimal climate of the San Francisco bay area, the majority of the conditioning of the spaces will be managed with passive strategies and natural lighting.





INTEGRATION passive

Day Lighting

The shading and passive heating strategies are controlled by the occupant needs. Light shelves run the entire length of south-facing glazing to diffuse sunlight. Light bounces from the extension, into the upper realms of the ceiling space and reflecting off the white space frame and wood slats.

During the winter, light penetrates far into the architecture and works with the slab to act as a passive heating strategy.

Light that pours through the roof fenestrations bounces in the roof structure, reflecting and diffusing. It then reveals itself through the voids of the columns. It is also filtered through the lattice woodwork before reaching the spaces below.

Graphs produced with DIVA.

Shading Schedule possibilities before Implementation of Automated Curtains

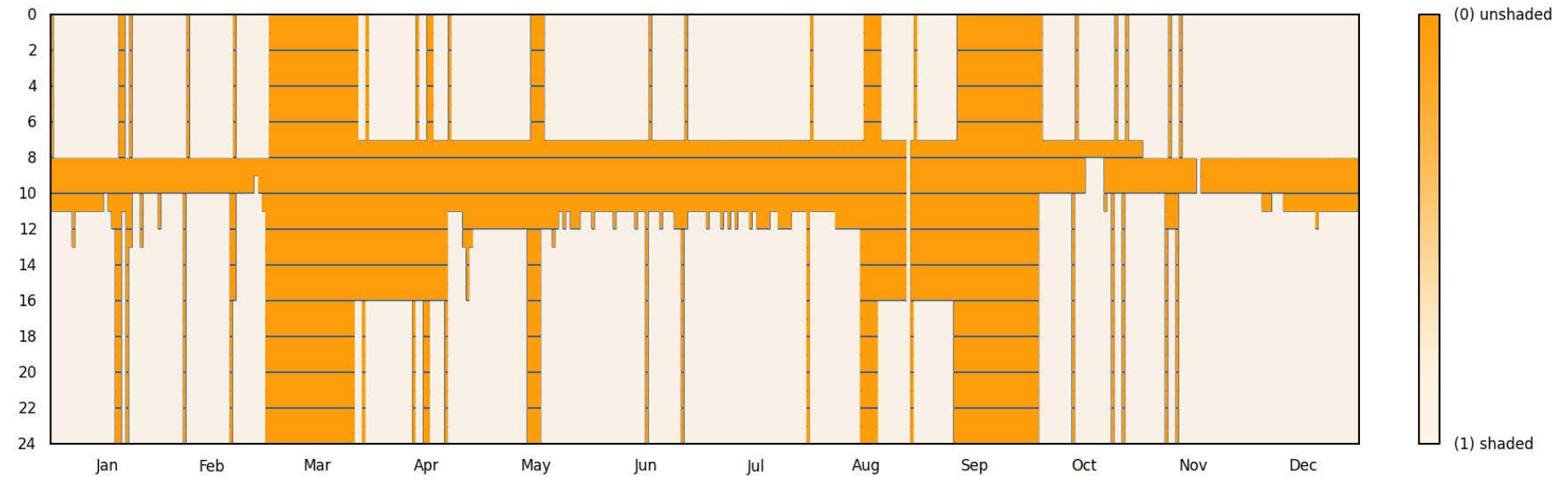

Glare Diagram
(calculated without shade system involvement)





INTEGRATION passive

Rainwater management took a front seat in the design process for this facility. The rainwater around the building is to be collected and filtered for usage within the building. Rock beds at the perimeter of the exterior aggregate as well as the central drain in the open courtyard will direct collected water through a sub-slab filtration system and into 10,000 gallon storage tank.

Rain screen facades will direct rainwater off the walls of the exterior walls and into the adjacent site rock beds. These beds will let water run into the landscape that borders the rain screen facades without being polluted with chemicals or other materials, irrigating the drought-resistant landscape.

The site will manage rainwater by utilizing bioswell retention areas. Placed in areas of high runoff, they may filter the runoff and provide naturally filtered, non-potable water.

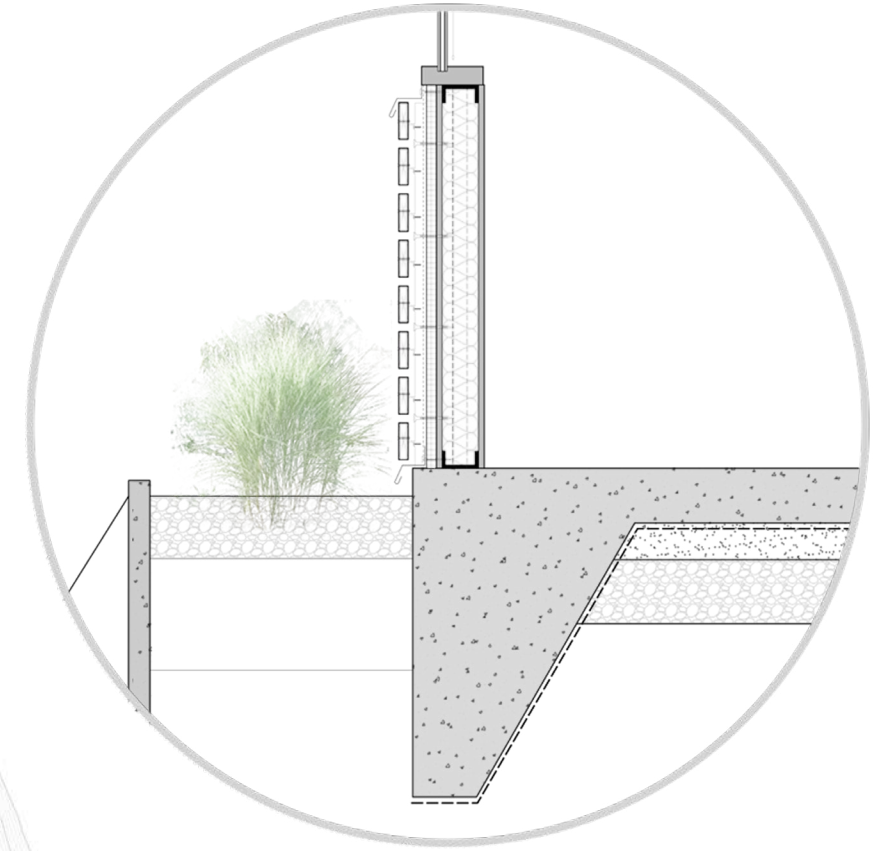



INTEGRATION passive

A combination of automated clerestory windows and nanawalls create the ideal passive cooling strategy through the three buildings of the campus. Both systems collapse to provide maximum comfort.

Rain water catchment is not prevalent for all months of the year in this climate, however for the few weeks that it does rain, it pours. An estimated 5,000 to 10,000 gallon cistern is needed for rainwater collection. The catchment strategy is not only for use in the buildings, but also a celebration of the importance of water to the site and studies at hand.

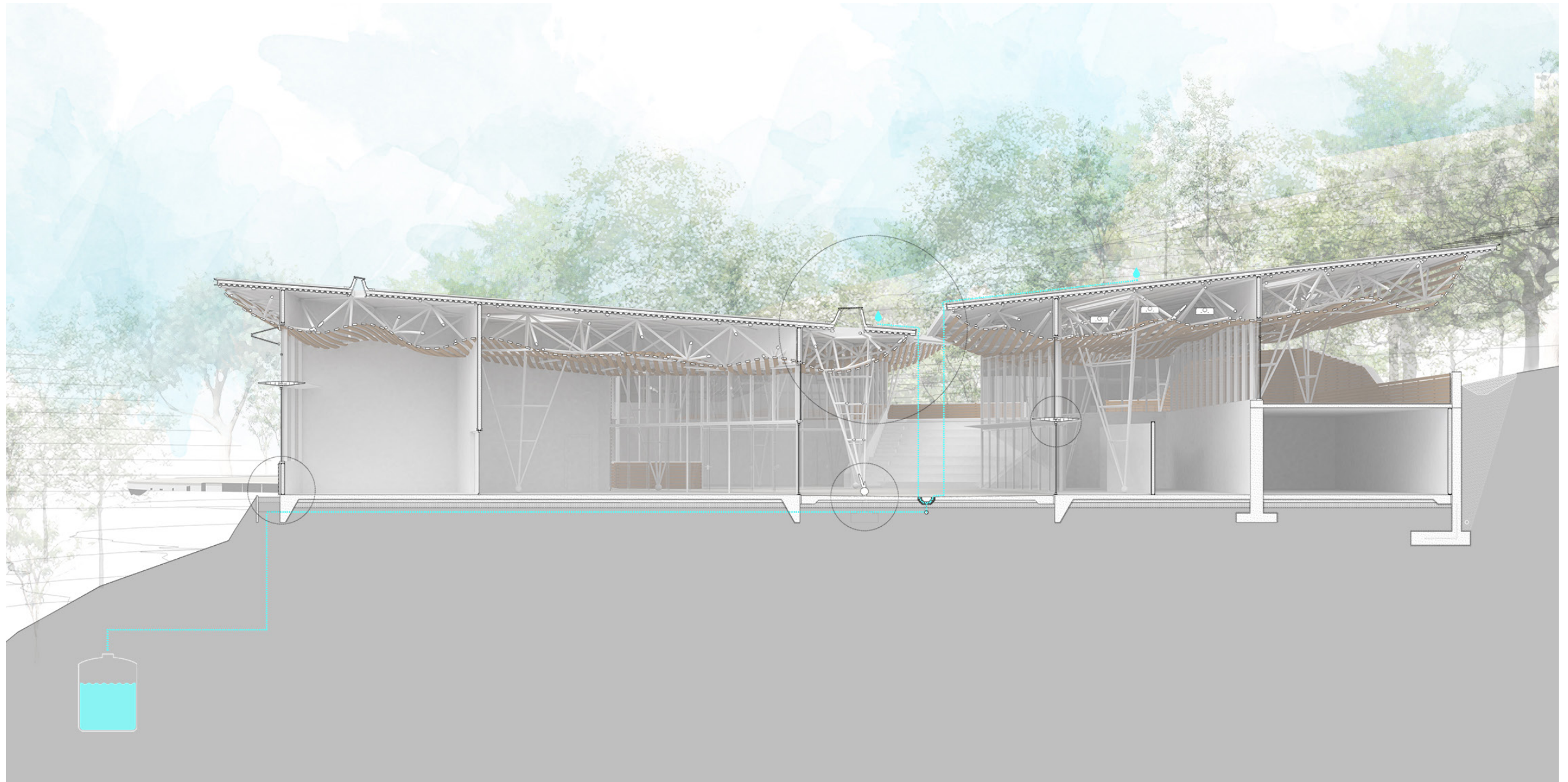



INTEGRATION active

The active systems are only meant to operate during the extremities of the bay area climate, which is limited between three and four months out of the year.

During said extremes, the active strategies derive from a closed loop geothermal system. This 32-well system connects to its prospective geothermal pump and then to an individual hybrid boiler-chiller per building. From there, the fluid is connected to a smaller pump that sends it to the active chilled beam system. Undesired air is sent to the beams and is filtered through coils that send out the desired temperature.

Fresh air is provided through an impregnated energy recovery ventilator, insinuating that it is equipped with a desiccant wheel. This wheel will help with humidity levels of the architecture as it transitions from a completely transparent state to a closed facade.

Active lighting is automated by occupant need. This linear lighting system gives extra aid to times of overcast daylighting or evening events that the center hosts. The occupancy sensors aid in an energy conscious environment.





INTEGRATION active

This plan shows the spaces of the maritime studies facility, portraying the dialogue of the exterior and the interior. The plan jogs in elevation along all edges of which the upper terrace meets the back edge of the building's programmed spaces. The building's life comes from natural sources as it was designed to be net zero. The system is shown in a state of heating, pulling heat from the earth through the medium of water in a closed loop system. The system is powered by electricity which is obtained through solar panels on the roof. Ventilated air is pumped from the exterior and a dehumidification process treats the air as it enters the spaces through the chilled beam system.

With an approximated 8,000 square feet, our space would need around 32 tons of conditioning. Each of the system's 32 wells reaches 300 feet of depth, delivering one ton per well, meeting the need for the conditioning of our square footage with any assistance needs being met by zone-specific hybrid boiler/chiller units.

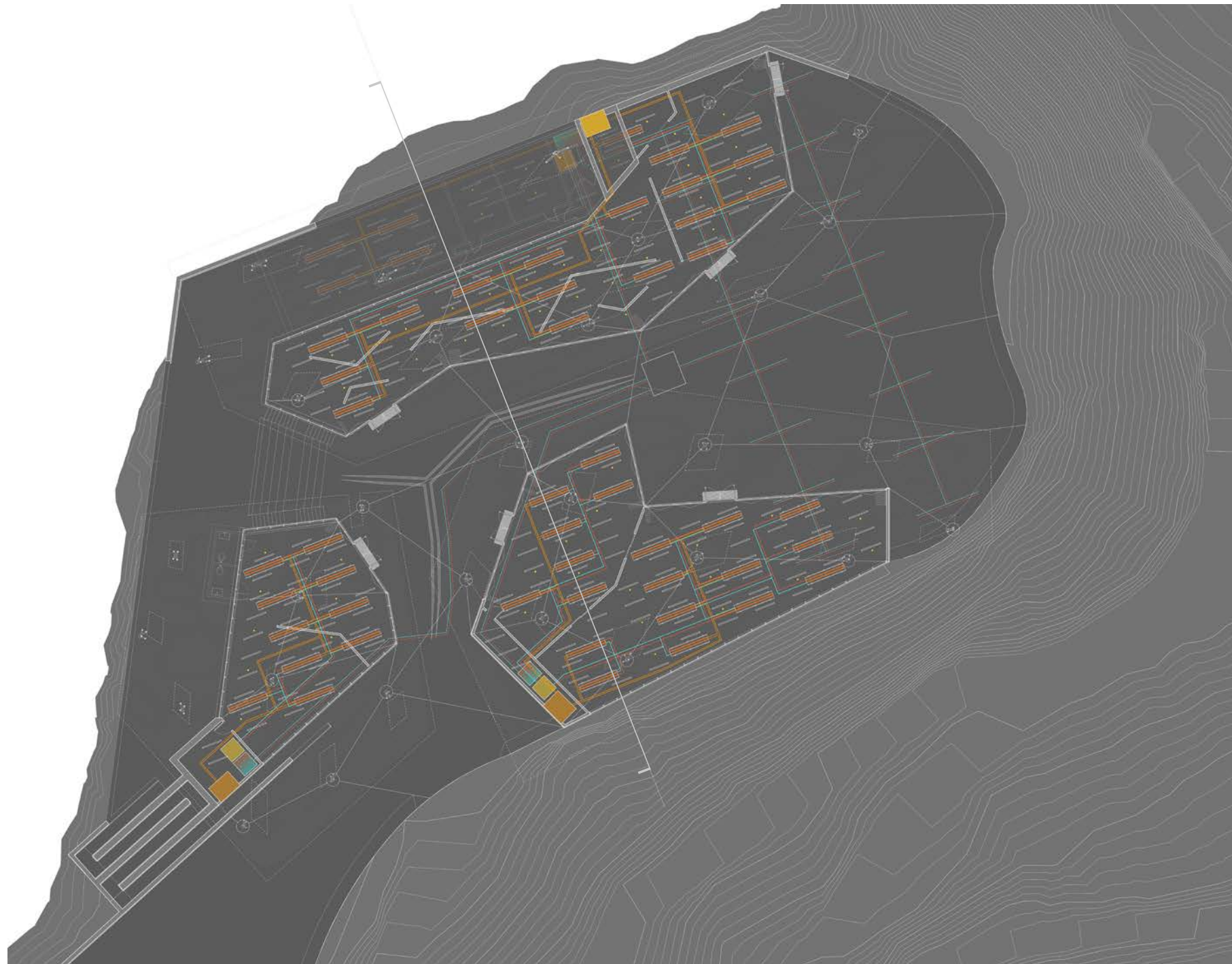

In addition to actively heating or cooling the spaces, the chilled beam system can also be used passively to circulate air and deliver fresh air to the spaces. Operable clerestory windows and an extensive nanawall system provide the availability for completely passive cooling and essentially a fully outdoor experience.

The energy recovery ventilator exhausts old air for fresh air from the exterior of the building. As it makes this exchange, it recycles and uses the heat from the exhaust air and heats the incoming air. The desiccant wheel addition aids in humidity issues. The silica gel pulls moisture out of the incoming air as well as a chilled coil that follows the desiccant wheel. These reduce the humid conditions and the likelihood of condensation in the building.



INTEGRATION active

Each of the 3 buildings is conditioned individually as they are separated into zones.

ZONES

- One hybrid chiller/boiler per
- HVAC zone (3 zones)
- One hydroponic pump per HVAC zone

Ventilation

- Energy recovery ventilator with desiccant wheel
- Impregnated with silica gel for dehumidification
- Post-ERV cooling coil to increase dehumidification factor
- Dehumidification used primarily after nanawall openings

Active Chilled Beam System

- Heating and cooling and air [re] circulation
- Smoke detectors
- CO2 sensors
- Sprinkler system

Activity Sensors

- Occupancy sensors
- Lighting sensors

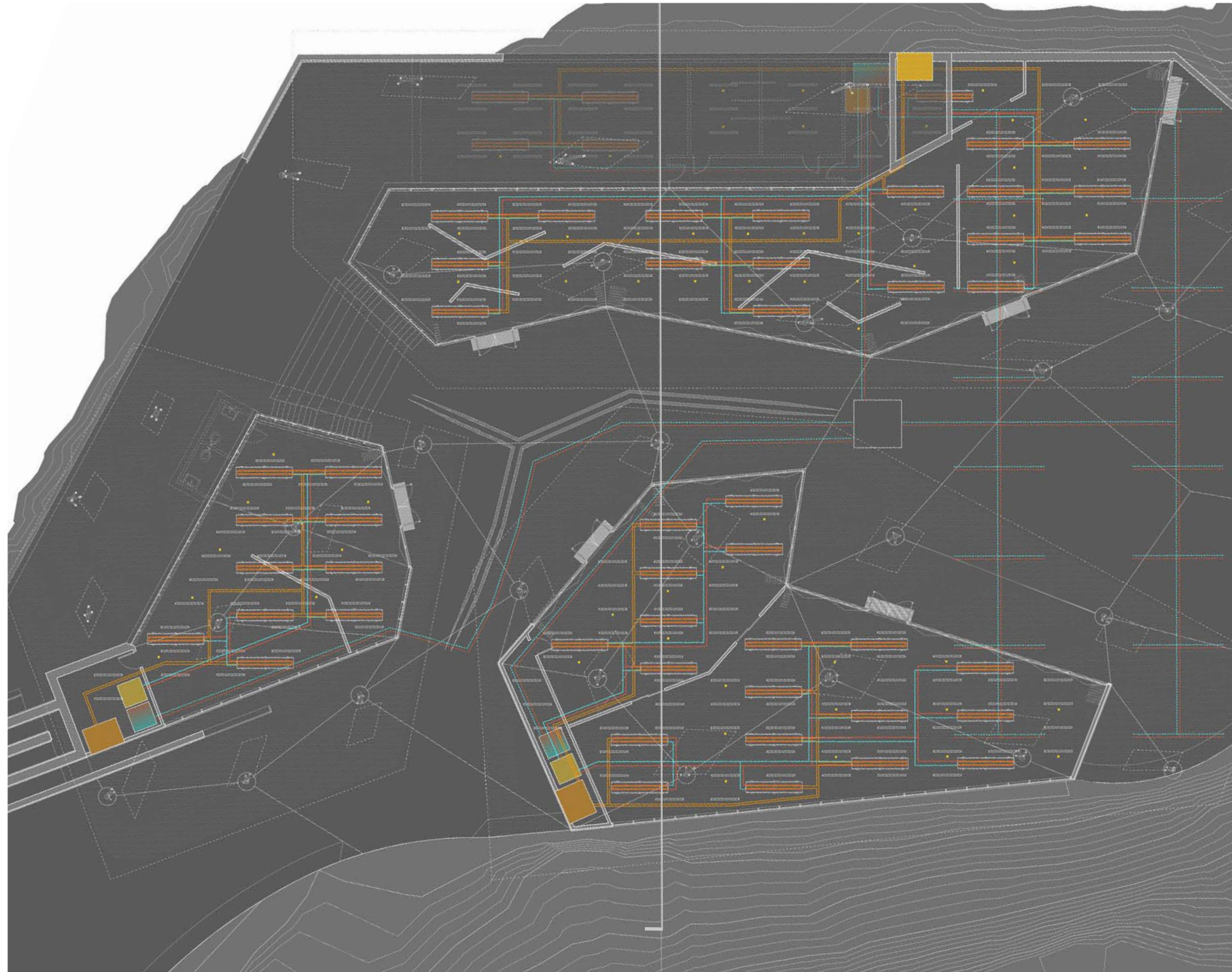

Lighting

- Phillips LED Line-Light system
- Skylight/daylighting strategies
- Operable and automatic system
- Shading systems with permanent light shelves

Surface Tension Lines

- Aggregate slabs throughout the facility,
- Slabs change state (raw, rough and polished) based on the condition (parking, exterior, interior)

Geothermal Closed Loop System

- 32 6" bore holes at a depth of 300' each.
- Large pump to push water through PEX piping loops and to perspective zones

Nanawall System

- Creates permeable program
- Dialogue between interior and exterior



INTEGRATION active

While passive strategies for lighting are used, such as utilizing sunlight for lighting purposes as well as heating, active strategies are involved in this process as well.

The light shelf that provides shade and glare resistance on south-facing walls with glazing is equipped with an automated shading system for lessened glare in harsh light when wide views are not a priority. The shading system will operate along with the conditioning system of the building. Whether it be the timer or the manual override by the occupants, the shading system is integrated into the system of occupancy, temperature and lighting sensors, playing a vital role in the reduction of energy use in the buildings.

Lighting of the interior spaces is controlled by the use of daylighting as well as a linear lighting system that hangs from the roof at heights that match the flowing slats attached to the space frame. The brightness of the lights will be automatically changed as the light sensors see fit, unless overridden by the occupants. Sunlight and artificial light will work in unison to create a comfortable environment for the users of the facility.

Graphs produced with DIVA.

Artificial Light Dimming Schedule

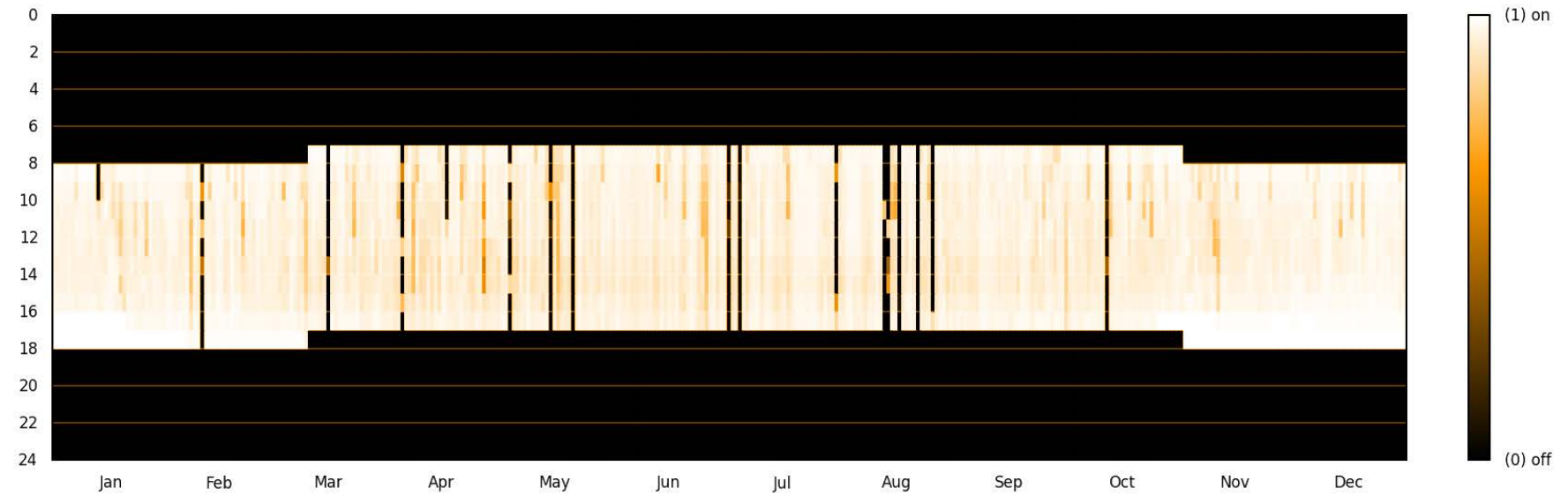

Shading Schedule possibilities after Implementation of Automated Curtains

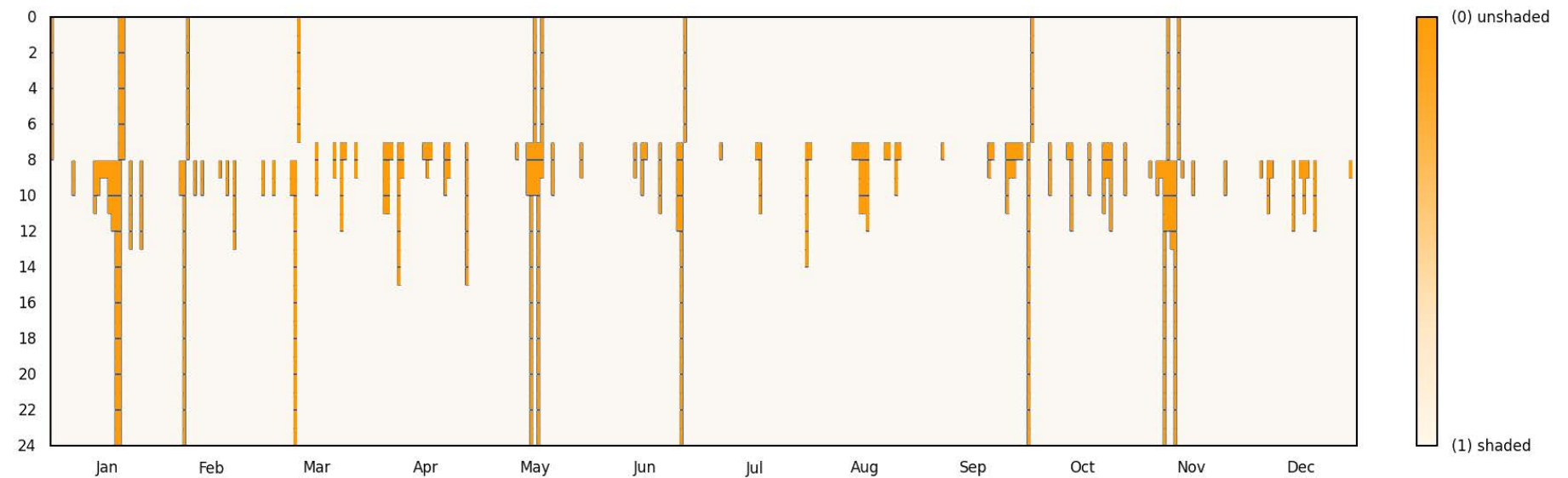

 APPENDIX



 APPENDIX

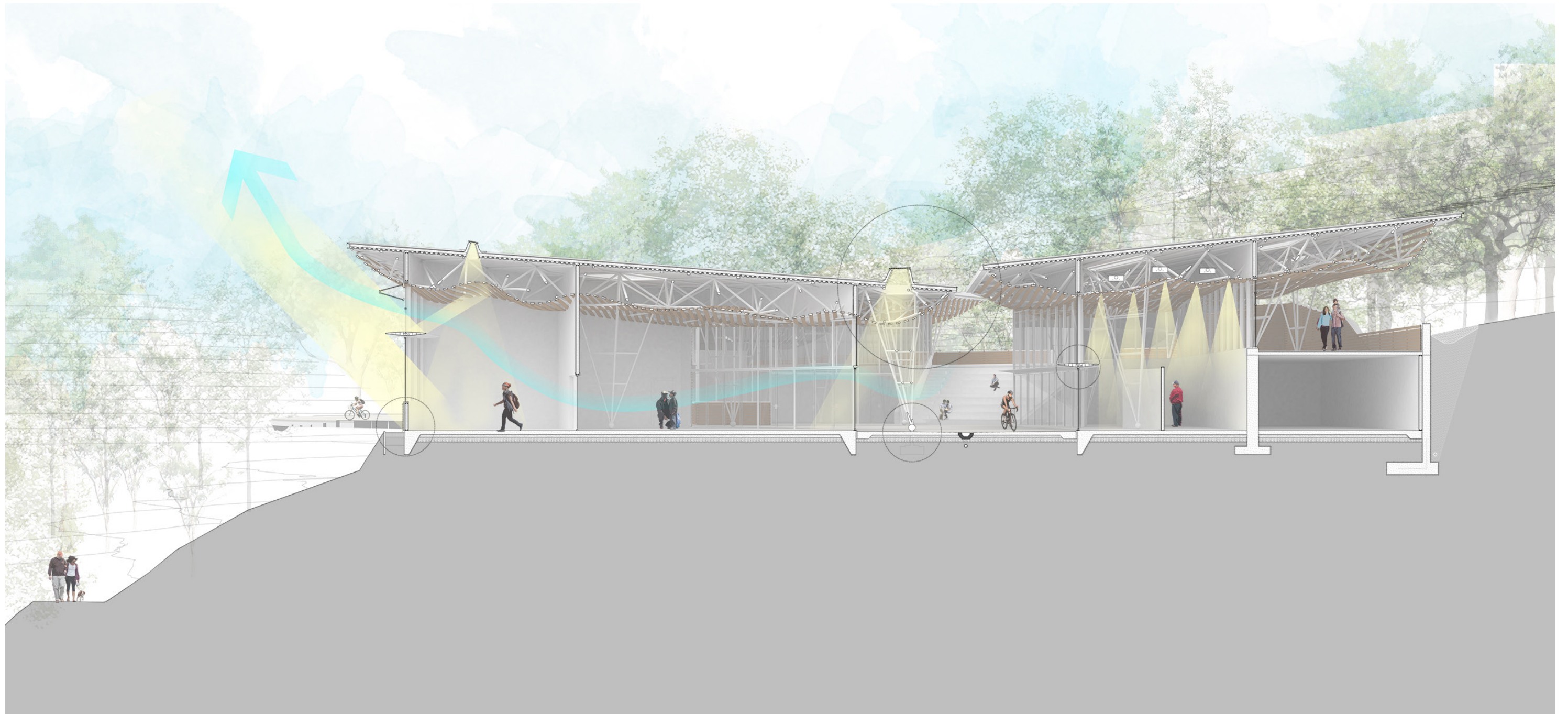

 APPENDIX

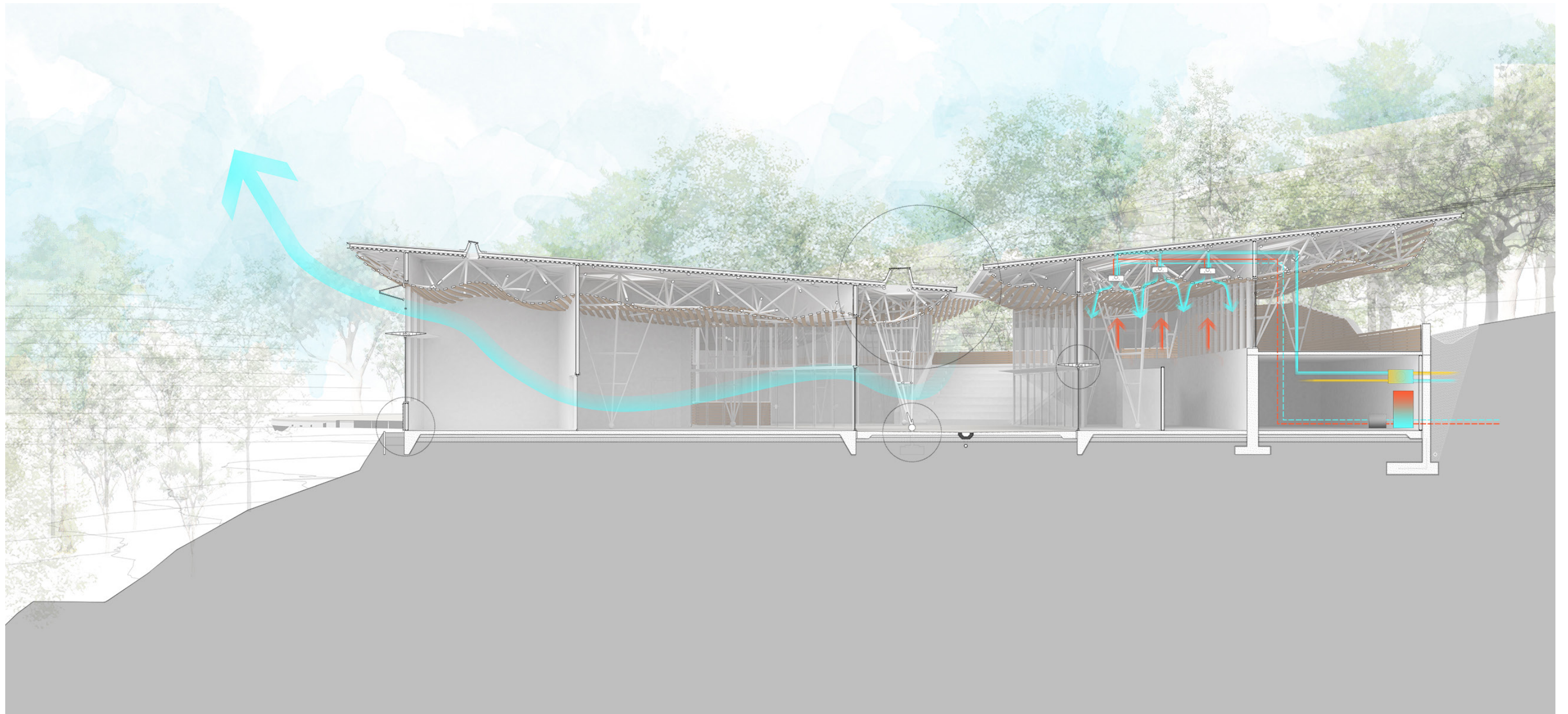

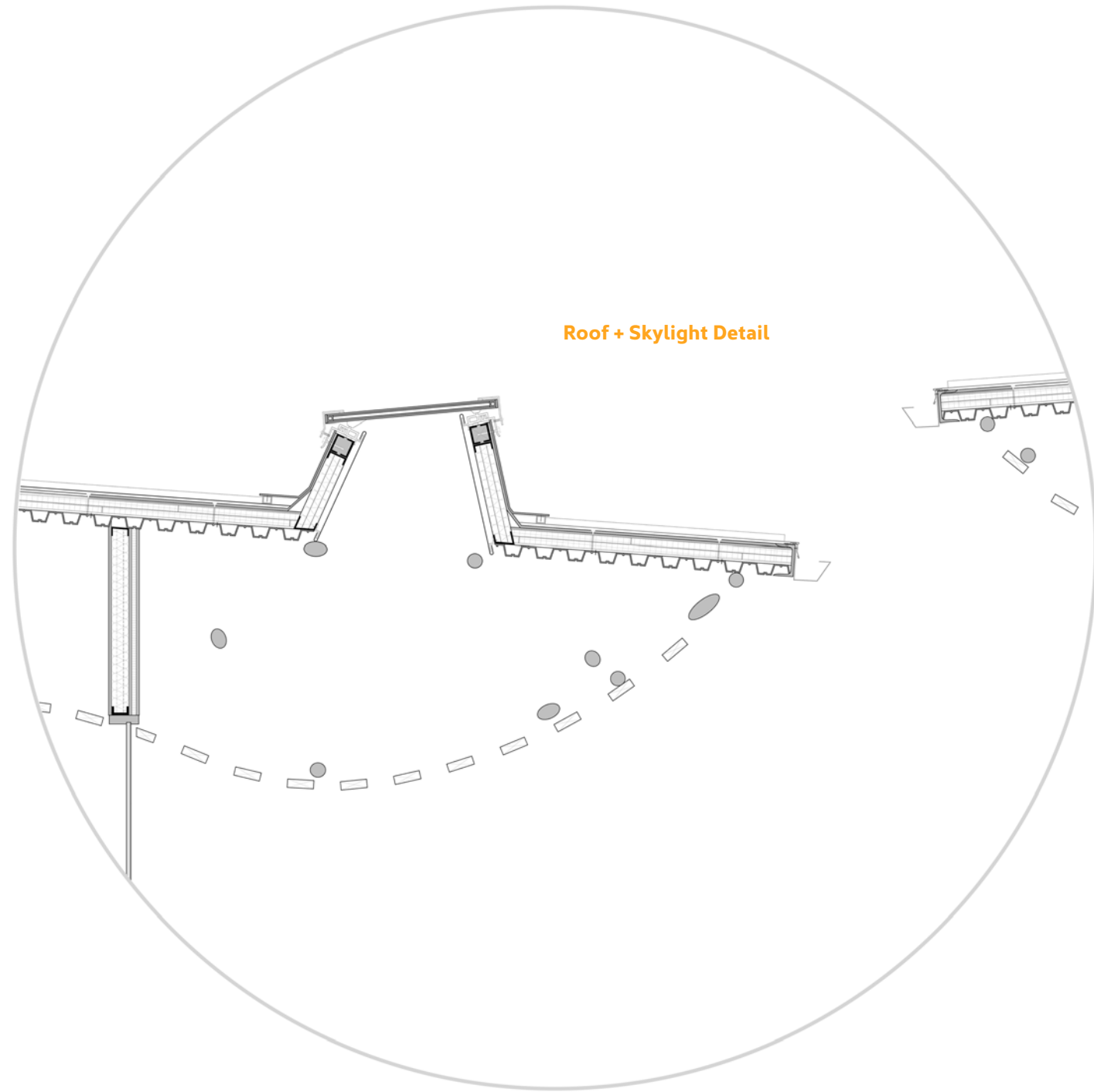
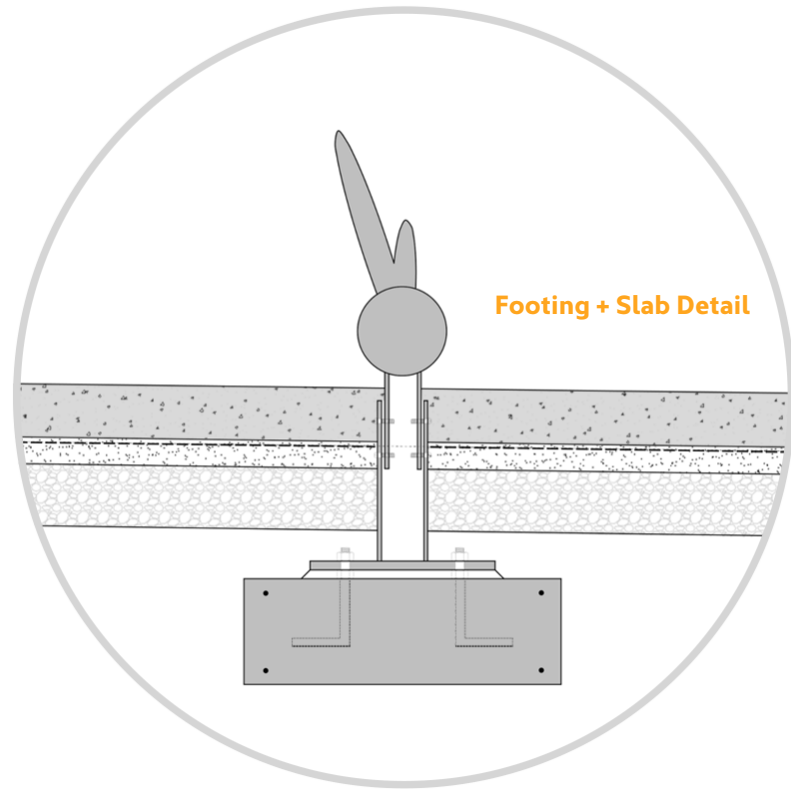

APPENDIX



 APPENDIX



terrace looking over amphitheater



APPENDIX

